

Tumble dryers

T4250, T4350

Features and benefits

- High productivity – 2 full loads per hour
- Low energy consumption for optimal efficiency
- Selection of temperature and time for easy operation
- Customized user panels for specific user needs – available for Coin – AHL (apartment house laundry) – OPL (on premises laundry)
- Large door opening for easy loading and unloading
- Large selfcleaning lint screen for easy maintenance
- Reversible door hanging for a convenient laundry flow
- Easy access to vital parts from front and rear for simple servicing
- Selecta Microprocessor control
 - 2 auto stop programs for extra dry and dry
 - 5 to 9 tailor made programs for any drying need
 - Accurate temperature control for unmatched drying accuracy
 - Anti-crease cycle for avoiding creasing if the dryer is not unloaded
 - Error codes for easy trouble shooting
 - High contrast display
- Serviceprogram for adjustment of parameters eg. temperature and cooldown time

Main options

- Stainless steel front
- Stainless steel drum
- Residual Moisture Control – RMC
- Reversing drum
- Payment: coinmeter, chipcard reader, CP connection
- Special versions (dryer + option package): Lagoon™ variant includes stainless steel front, stainless steel drum, RMC and reversing drum
- Fresh air intake
- Supply disconnecter
- CMIS (Certus Management Information System)



Main specifications			T4250					T4350			
Rated capacity,	filling factor 1:18	kg/lb	13.9/30					19.4/42			
	filling factor 1:25	kg/lb	10/22					14/30			
Drum volume		litre	250					349			
Drum diameter		mm	760					760			
Heating alternatives											
	electric	kW	6/9/13.5					13.5/18			
	gas	BTU/h (kW)	46 000 (13.5)					71 700 (21)			
	steam at 800 kPa	kW	25					25			
Consumption data*			6 kW**	9 kW	13.5 kW	Gas	Steam	13.5 kW	18kW	Gas	Steam
Total time at 11/16 kg		min	36	36	27	27	18	38	27	24	22
Energy consumption at 11/16 kg		kWh	3.9	5.5	5.8	6.2	13	8.2	7.7	8.4	11.7
Evaporation		g/min	111	160	214	211	326	211	289	342	359
Energy kWh/litre water evaporated		kWh/l	0.98	0.95	1.02	1.09	2.23	1.02	0.99	1.03	1.48

* At rated capacity 100% cotton load at 50% initial moisture dried to 0%.

** Test load 8.2 kg/18lb

Electrical connections*		T4250	T4350	
Heating El.	Voltage			
	200-240V 3AC 50/60 Hz	kW(A) 10.3 (35)	14.5 (50)	
	200-240V 3AC 50/60 Hz	kW(A) 14.5 (50)	19.3 (63)	
	200-230V 1AC 50 Hz	kW(A) 6.6 (30)	-	
	400-415V 3AC (N)** 50 Hz	kW(A) 10.3 (16)	14.5 (25)	
	400-480V 3AC (N)** 60 Hz	kW(A) 10.3 (16)	14.5 (25)	
	400-415V 3AC (N)** 50 Hz	kW(A) 14.5 (25)	19.3 (35)	
Gas/Steam	400-480V 3AC (N)** 60 Hz	kW(A) 14.5 (25)	19.3 (35)	
	120V 1AC 60 Hz	kW(A) 1.1 (10)	1.1 (10)	
	230-240V 3AC 50/60 Hz	kW(A) 1.1 (10)	1.1 (10)	
	230V 1AC 50 Hz	kW(A) 1.1 (10)	1.1 (10)	
	400-415V 3AC 50 Hz	kW(A) 1.1 (10)	1.1 (10)	
400-480V 3AC 60 Hz	kW(A) 1.1 (10)	1.1 (10)		
Steam, gas and air connections				
Steam	ISO 7/1-R	1"	1"	
Steam pressure	kPa	100-1000	100-1000	
Steam consumption	kg/h	65	65	
Condensate	ISO 7/1-R	1"	1"	
Gas	ISO 7/1-R	1/2"	1/2"	
Gas pressure	Natural gas	Pa	2000	2000
		mbar	20	20
	Propane	Pa	2800-5000	2800-5000
		mbar	28-50	28-50
Air outlet	ø mm	200	200	
Evacuated air,	el 6/9 kW	m³/h	360	-
	el 13.5 kW		600	600
	el 18 kW		-	1000
	gas 13.5 kW		600	-
	gas 21 kW		-	1000
	steam		1000	1000
Pressure drop	el 6/9 kW	Max. Pa	650	-
	el/gas 13.5 kW		520	520
	el 18 kW/gas 21 kW/steam		270	270
Sound levels				
Airborne sound level	dB(A)	<70	<70	
Heat emission				
% of installed power, max		15	15	
Shipping data				
Weight	net, kg	161	169	
Shipping volume	crated, m³	1.57	1.92	
Dimensions in mm				
A	Width	790	790	
B	Depth, el and gas	900	1120	
	Depth, steam	1100	1320	
C	Height	1720	1720	
D		840	840	
E		790	790	
F		155	155	
G		170	170	
H		1505	1505	
I		100	100	
K		1565	1565	
L		80	80	
M		395	395	
N		755	755	
O		585	585	
P	El and gas	1620	1860	
Q	Steam	1820	2040	
Q		740	740	
1	Door opening ø 580	5	Steam connection	
2	Control panel	6	Condensate connection	
3	Electrical connection	7	Exhaust connection	
4	Gas connection			

* Other voltages available, see installation manual.

** N is selected when using external connection.

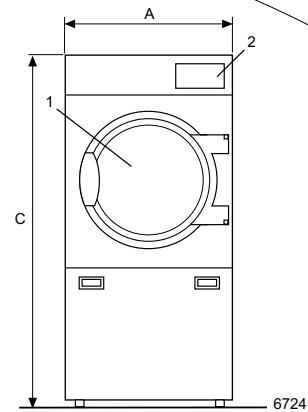

Front

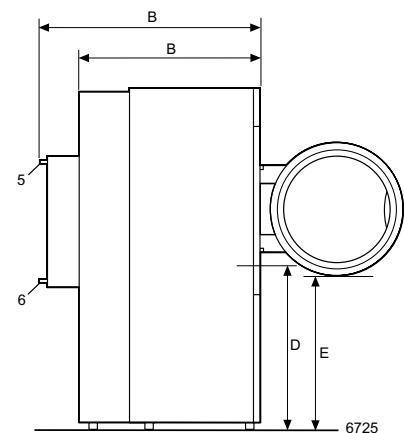

Left side

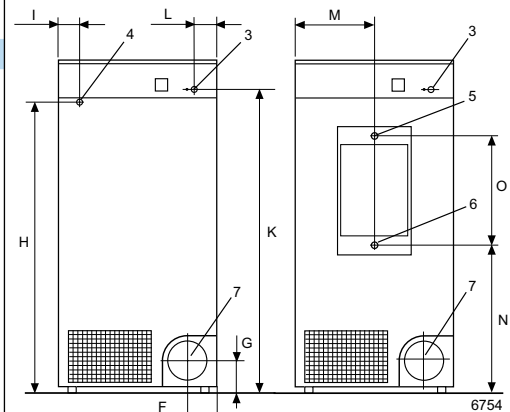

Rear side

